

Move your life.

# wagner

## W-Table®

Art.-Nr.: WT180..(900x1800)  
Art.-Nr.: WT220..(1100x2200)



## ABMESSUNGEN

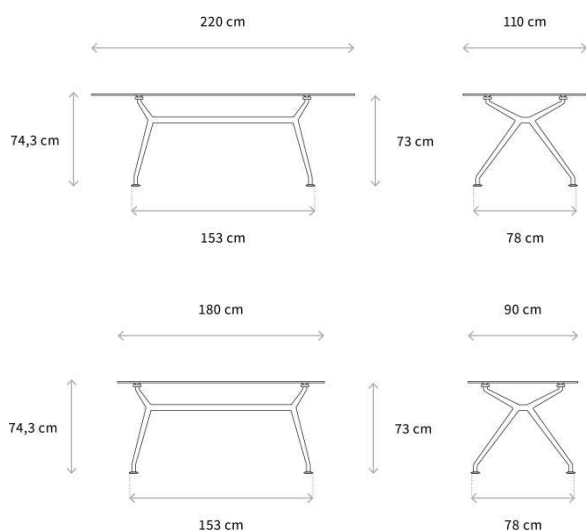

Gewicht ab ca. 50 kg

## LINKS



WAGNER - Eine Marke der TOPSTAR GmbH | Augsburgener Straße 29 | 86863 Langenneufnach | TEL 08239 - 789 166 | FAX 08239 - 789 199 |  
info@wagner-living.de | www.wagner-living.de | 02.05.2018

## AUSSTATTUNG

Prämiertes Design-Tischgestell aus poliertem Aluminium bzw. graphitschwarz matt oder massives Eichenholzgestell, nahezu astlos, Stärke 30-50mm, alle Kanten gefast, zwei massive Aluminiumverbinder poliert

Strapazierfähige Tischplatten im Format 900x1800 mm oder 1100x2200 mm; wahlweise mit moderner HPL-Kompaktplatte, elegante Glasplatte satiniert oder massiver Eiche

Tischfüße ausgerüstet mit Quick-Klick-Fußgleitersystem für Teppichböden

Bei Version Tischplatte in Eiche massiv geölt; 40mm starke Asteiche, durchgängige Lamellen, gesunde Punktäste bis 35mm, Kanten mit umlaufender Fase 3-4mm

## PLATTEN

Hartfaserplatte weiss 14mm (HPL-beschichtet)  
ESG-Verglasung mit polierten Kanten und satiniertes Oberfläche  
Eiche massiv

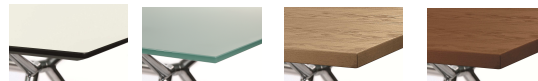

## GESTELLFARBE

Aluminium poliert

Aluminium graphitschwarz matt

Massives Eichenholzgestell



## OPTIONEN

Quick-Klick-Fußgleiter mit Filzeinsätzen für harte Böden

## FACTS



\* gem. den Wagner Garantiebestimmungen. Für den Einsatz im gewerblichen Gastronomiebereich gilt eine gesonderte Garantie.

Move your life.

# wagner

## W-Table®

Item no.: WT180..(900x1800)  
Item no.: WT220..(1100x2200)



### DIMENSIONS

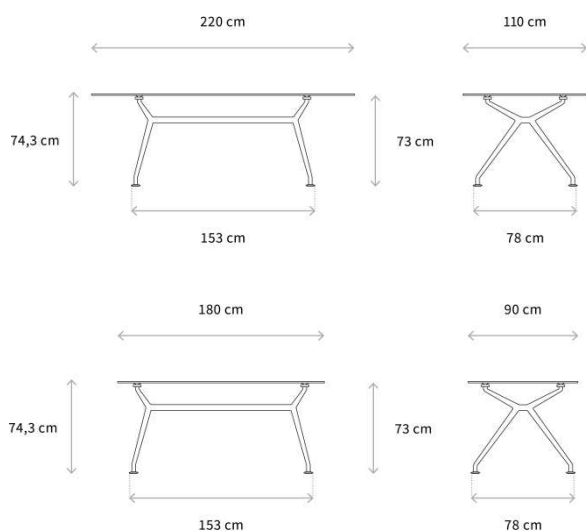

Weight: approx.. 50 kg

### LINKS



WAGNER - Eine Marke der TOPSTAR GmbH | Augsburgener Straße 29 | 86863 Langenneufnach | TEL +49 8239 - 789 166 | FAX +49 8239 - 789 199 |  
info@wagner-living.de | www.wagner-living.de | 27.11.2018

### EQUIPMENT

Award-winning design table frame made of polished or graphite black mat aluminium

Solid table tops in the size 900x1800 mm or 1100x2200 mm; optionally with modern laminate table top, elegant glass top satin-finished or with solid oak wood

Table feet equipped with quick-click foot glide system for carpet floors

If you order the table top made of solid, oiled oak wood: 40 mm strong laminated knotty oak wood, continuous fins, healthy pin knots up to 35 mm, edges with circumferential chamfer of 3 - 4 mm

### PLATES

Laminated white plate 14mm, ESG-glass with polished edges and satin-finished surface  
Solid oak

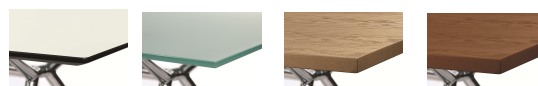

### FRAME COLOUR

Aluminium polished

Aluminium graphite black matt



### OPTIONS

Quick click foot glides with felt inserts for hard floors

### FACTS

